

GP7/9 Drop-In Decoder Modification

For Old Style GP7/9 Lighting Boards

Older models of the USA-Trains GP7/9 chassis use high voltage incandescent bulbs in the lighting boards. These are not compatible with the GP-7 Drop-In decoder which is designed for the present production chassis that uses lower voltage bulbs.

However, the decoder may be modified to drive the higher voltage bulbs although it is not a trivial task.

The modification requires cutting a circuit track (called a trace) on the back of the Drop-In decoder circuit board to disconnect a pin on U4. Once the trace is cut, the pin is connected to another location on the decoder using a piece of insulated wire. Once modified, the lighting boards can plug into the decoder. With this change, the lighting boards are not modified in any way and will offer standard operation with the F0 key and correct color display of the marker lights.

Once this change has been made, the lamps will use the full battery voltage as their source.

Warning: If you perform the modification yourself, the decoder warranty will be voided. Take care and work carefully. If you damage the board, standard repair charges will be assessed.

However, if CVP performs the modification, full warranty applies. However there is a charge for this service. Contact CVP for current pricing on the modified decoder.

Step 1: Locate the proper trace. Turn the board over so that the back side is face up. Gently arrange the connecting cables so they are not pinched during the cutting process. The proper trace must be identified. The red arrow points at the trace to be cut. Double and triple check since cutting the wrong trace can cause lots of problems including damage to the decoder. This trace comes from U4, pin 2.

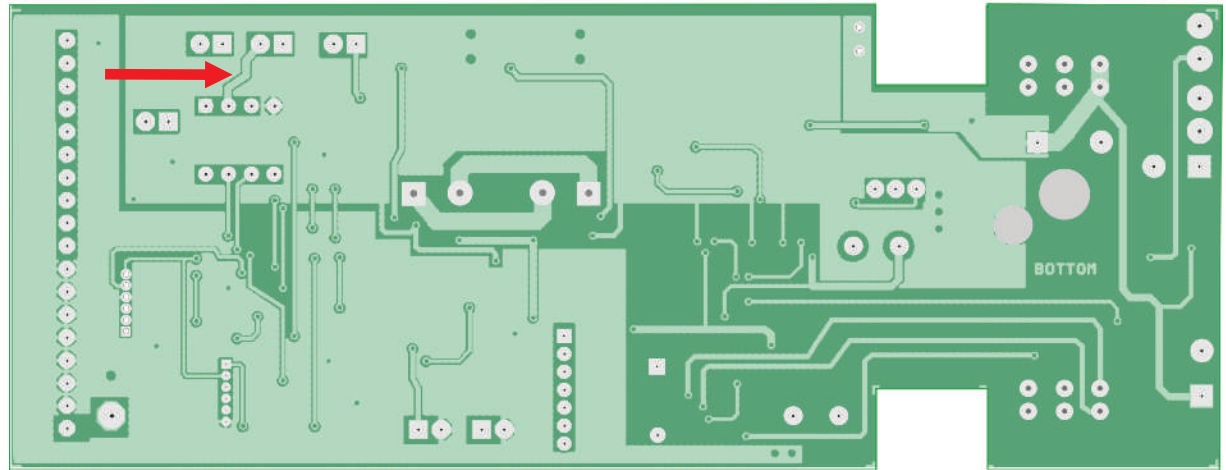

Step 2: Complete cut and sever the trace. Use a sharp X-acto knife to completely cut all the way through the green coating and then all the way through the underlying copper. Cut in both places indicated with the red lines. Now remove the copper between the two cut points, shown in white. Use the blade to dig under a corner of the cut trace and then peel it towards the other cut point. This will insure that the copper trace totally removed. Failure to completely sever the trace will result in a damaged decoder.

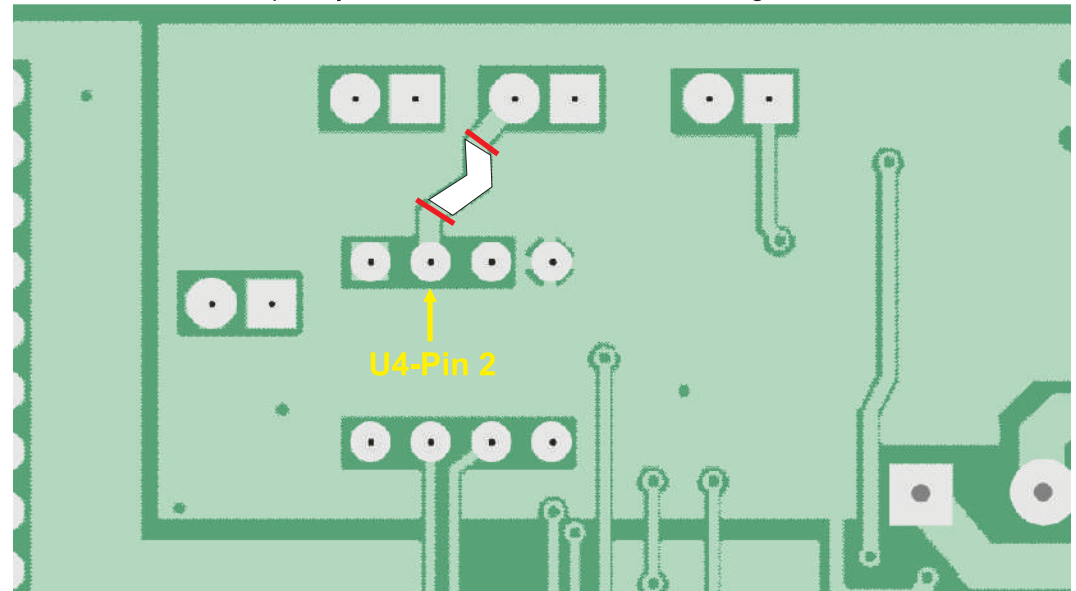

GP7/9 - modified
for old style chassis

3-5-11

©2011 CVP

CVP PRODUCTS
P.O. Box 835772
Richardson, TX 75083

May not be reproduced or copied

Step 3 - The Final Step: Connect a piece of insulated wire, small diameter is OK, from U4 pin 2 to the location shown - called a pad. The wire can be inserted into the pad and soldered on either the top or bottom side of the decoder.

Make sure you do not bridge between the other pins of U4. Neatness counts so take care not to splash solder on the board near pin 2. The solder does not have to be thick, but just enough to tack the wire to the pin. Don't worry about heating U4's pin or solder joint. The chip is designed to handle the heat of soldering.

Compare your job to the drawing and make one last check that you have cut and removed the trace, soldered the jumper wire to the proper pin of the chip and soldered the other end into the pad on the board.

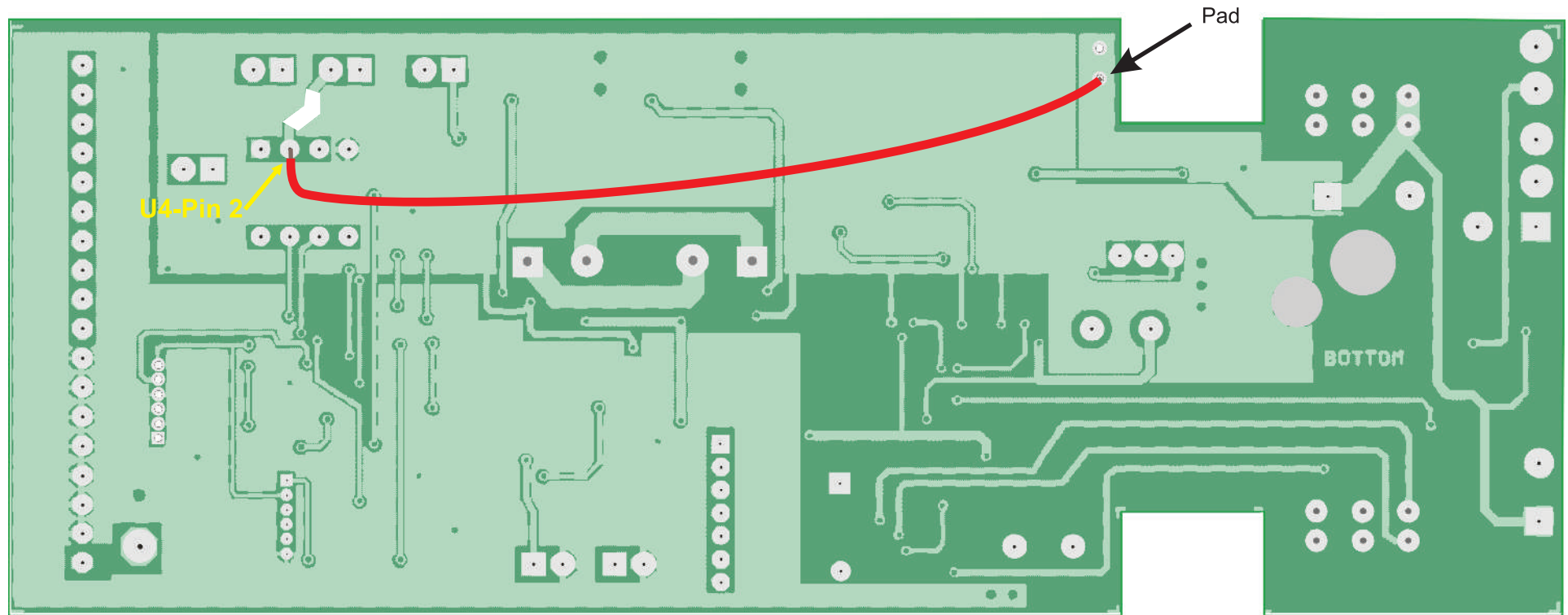

This is a picture of what the solder joint should look like on U4 pin 2 with the wire attached.

When using stranded wire, make sure all strands are soldered. Make sure no loose strands touch adjacent pins.

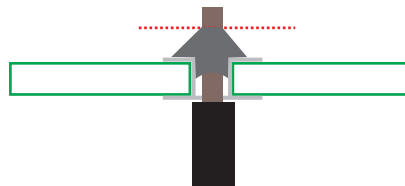

The other end of the wire solders into the pad. Solder form the top side of the board. Trim any excess wire (red dotted line) but don't cut off the solder joint.

GP7/9 - modified
for old style chassis

3-5-11

©2011 CVP

CVP PRODUCTS
P.O. Box 835772
Richardson, TX 75083

May not be reproduced or copied