

More Installation Accessories

Ultra-Miniature 2-Pin Plug and Socket (Not Polarized)

Military-grade connectors custom made in the USA. Has 3 inch rugged Teflon coated wire pigtails The pin pitch is 1.27mm but the plastic housing is extremely small. Each connector is sold separately.

UMPr Ultra-miniature Plug with wires
UMSr Ultra-miniature Socket with wires



Drop-In ALT Lighting Pigtail

For use on all Drop-Ins that offer an ALT lighting socket.

ALT6r Pigtail with 24 inches of wire



Plug To Fit Drop-In Charging Jack

Fits the battery charging jack on the bottom of the Drop-In decoder. Right angle plug. 2.1mm ID, includes 72 inches of polarized wire.

DICPr DC Plug with attached wire



USB to microUSB Charger Cable

Fits the microUSB jack found on AirWire throttles with rechargeable batteries. The 3 foot cable is bright orange.

USB2micror Charger cable for microUSB



0.5A Boost Module [suitable for HO locomotive motors]

Imported miniature voltage boost module. Boosts 3.7V to 12V. Accepts up to 9V input. Higher output current with higher input voltage. Maximum output current is 0.5A with 6V input. Overheat protection. No protection against short circuits. Has 0.1 inch pitch pins. LxW = 0.81 x 0.39 inches (not including pins). Requires soldering.

B05r Boost Module 3.7V to 12V @0.5A



Replacement Faceplate Screws For Wireless Controllers

Over time, the small faceplate screws used on the wireless controllers can loosen and fall out. This can render the throttle keys unusable. Always replace the screws if they fall out. The T5000 and T1300 use #2 Button Head screws. The T2300 and T6000 use #2 Cross Head screws.

BH#2r Pack of 10 Button Head Screws

CH#2r Pack of 10 Cross Head Screws



Button Head



Cross Head

Price List and Ordering

An Up To Date Price List Is Available From the CVPUSA Website

Purchase From Authorized AirWire Dealers or Direct From CVP. The authorized dealer list is on the CVP website. Just click on AIRWIRE DEALERS. Many dealers offer discounts off our list prices.

You may also directly order from us although we sell only at list price. An order blank can be downloaded from our website. You can fill it in and email or mail it to us. Or you may call us during our normal business hours.

Shipping costs are not included in the price list. We do not add a handling charge. Whatever the postal service charges us is what you pay for shipping.

CVP Products www.cvpusa.com 972-238-9966

Plug-In, Drop-In, AirWire, AirWire900, AIRWIRE, C60, C25, C15, G4X, CONVRTR, and the AirWire logo are registered trademarks of CVP Products. © 2003-2026 All Rights Reserved

AIRWIRE[®] 900

Battery Powered Wireless DCC Control For All Scales

We Make "Dead-Rail" Practical

Download the latest price list from the www.cvpusa.com home page.



Look For This Symbol Marking Exciting New Products

Designed, Manufactured and Serviced By CVP Products

www.cvpusa.com



In this catalog you will find QR codes that will take you to specific pages on the CVPUSA website. Scan the code to go directly to the appropriate webpage for detailed info! The QR code on this page takes you to the CVPUSA home page.



To setup to use AIRWIRE with your trains, here are the 3 basic items you will need to convert your favorite locomotive into an AIRWIRE wirelessly controlled, battery powered locomotive.

1 The AIRWIRE T6000 throttle is required. The throttle is used to setup the locomotive's decoder to suit your particular operating requirements. The same throttle is also used to run the locomotive. It is simple to use and very rugged - a perfect match for your enthusiastic, youthful operators. No other systems are required to setup or operate your AIRWIRE equipped locomotive fleet.

2 An AIRWIRE Decoder is needed if your locomotive doesn't have a DCC decoder already installed. There are several styles and sizes available. Some AIRWIRE decoders are designed to fit into specific locomotives and use the locomotive's existing factory wiring. For locomotives without a specifically designed AIRWIRE decoder or DCC socket, use the generic G4 decoder with 120 Watts of power or the very small M15 microDecoder designed for HO scales.

If your locomotive already has a built-in NMRA-DCC decoder, or you want to install a 3rd party DCC sound plus motion decoder, then you will need one of our popular AIRWIRE CONVRTRs™. The CONVRTR series comes in several different sizes, mounting methods and amperage ratings. The CONVRTR series allows any NMRA-DCC compliant decoder to be setup and operated with an AIRWIRE wireless throttle. No 3rd party DCC systems are required for any type of AIRWIRE installation.

3 The Lithium-Ion rechargeable battery and battery charger are needed. CVP sells two of the most popular battery sizes used for the larger scales, the BAT2 and BAT3 both rated at 14.8V. These are used in most O-scale and G-scale installations. Fortunately, AIRWIRE decoders can use just about any brand or type of battery. Battery sources for smaller scales are discussed C15 CONVRTR User Guide. Download it from cvpusa.com website.

Considerations and Suggestions

Changing over to battery power and AIRWIRE is not difficult. But, there are some considerations and decisions to make. If this is your first time to use battery power, the tips below will save you a lot of time and effort. It will also insure your very first installation is a first-time success.

Carefully Choose Your First Locomotive: Don't select the smallest locomotive in your fleet since it will provide you with the biggest challenge - finding space for the battery. Pick a locomotive that has plenty of space for the battery. It is OK to use a dummy locomotive or a trailing box car to hold the battery and the decoder.

Invest in quality tools. Get rid of your 100W soldering gun! Check out our appnote for tool recommendations. Scan the QR code or go to the app notes in AIRWIRE doc center.

Read and Follow The Installation Guide. We have found that a true genius is a person who not only reads the installation guide, but the also follows the instructions.

Authorized AirWire Dealers offer all of our AIRWIRE products as well as other products that work with AIRWIRE. Many dealers also offer installation services. Please contact them directly for details or to purchase AIRWIRE products.



T6000 Wireless Controller

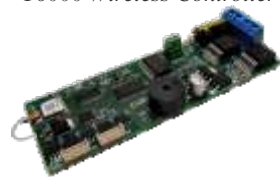

G4 120W Decoder



C15X CONVRTR™



Li-Ion Battery



Whip Antenna Extension Cable

A low cost solution for moving the small whip antenna up to 14 inches away from the AirWire radio module used on decoders and CONVRTRs. The whip antenna snaps off the radio module and snaps onto one end of the extension cable. The other end snaps onto the radio module. No tools or soldering required.

WECr Whip Extension Cable 14 inches



External Antenna Adapter Cable

6 inches of miniature coaxial cable with a UFL plug on one end and a REV SMA jack at the other end. The UFL plug matches the external antenna jack found on any "X" decoder or X series CONVRTR.

UFLADAPTr UFL plug to REV SMA jack



External Dome Antenna

Low profile "dome" antenna. Can be painted with non-metallic paint. The dome is attached to 9 inches of RG174 coax cable and plug. Requires the External Antenna Adapter Cable.

DCAr Dome Style External Antenna



Replacement Whip Antenna

Fits all decoders and CONVRTRs having an X part number. Has the UFL connector along with the clear plastic insulated antenna wire trimmed for the ISM 915MHz band. Black heatshrink tubing protects the junction of wire to connector. Snaps onto radio module. No tools needed.

ANTWr Replacement Whip Antenna



Adapter Board For Aristo Locomotive's DCC/RC Socket

This plug-in adapter plugs directly into all Aristo locomotives having the DCC/RC Port (socket). It has clearly marked terminals and a self-resetting fuse to protect your battery pack. User guide included.

Ada1r Fully Assembled

Ada1kr Kit of parts that requires soldering

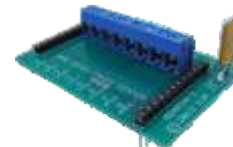

JST 2.5mm Plug or Socket

The SKT is the matching socket for the CVP battery pack plug. The PLUG is the same as found on the CVP battery pack. Each connector includes 12 inches of flexible red and black stranded wire.

JST-SKTr Socket with 12 inches of wire

JST-PLUGr Plug with 12 inches of wire

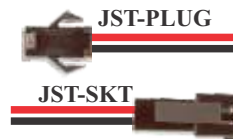

2mm Polarized Connector [Pack of 5 Of Each Type]

Popular, inexpensive, 2mm pitch male and female connectors. Comes in package of 5 all the same type. Select male or female. Has 6 inches of red and black wire. Female socket type fits our BAT4 plug.

5PACKFr Package of 5 female connectors

5PACKMr Package of 5 male connectors



1.27mm Polarized Connector Set

Very small and inexpensive connector. Perfect for use in small scales. One each male and matching female connector. Has 3 inches of red and black wire that are pre-stripped and tinned.

CON127r DC Plug with attached wire



Lithium-Ion Rechargeable Batteries And Chargers

Wireless Controllers

14.8V 6.8Ah Battery Pack*

Rated at 6.8A continuous discharge with a 14A peak discharge, the BAT2 pack is ideal for the high current dual motors found in the USA-Trains diesels. It can power a USA-Trains SD70 for more than 3 hours. The battery is fully protected with an automatic cutoff at the end of the charge.

This battery offers long life, high capacity and nearly constant output voltage over the life of the charge.



BAT2

The dimensions are 2.9 x 2.8 x 1.5 inches. It weighs about 16 ounces and comes with a JST 2.5mm connector to match CVP's Plug-In and USA-Trains Drop-In decoders.

14.8V 3.4Ah Battery Pack - "The Brick"*

Rated at 4.9A continuous discharge with a 6A peak discharge, this small pack is ideal for locomotives with limited space. It easily fits the USA-Trains NW2 switcher, the S4 switcher and Bachmann's C19 steam engine. The battery is fully protected with an automatic cutoff at the end of the charge.



BAT3

This battery offers long life, high capacity and nearly constant output voltage over the life of the charge. The dimensions are 2.75 x 1.46 x 1.46 inches. It weighs about 8 ounces and comes with a JST 2.5mm connector to match CVP's Plug-In and USA-Trains Drop-In decoders.



Part#	Description
BAT2r	14.8V @ 6.8Ahr Protected Lithium-Ion Battery Pack
BAT3r	14.8V @ 3.4Ahr Protected Lithium-Ion Battery Pack

Smart Lithium-Ion Battery Chargers

The Smart Lithium-Ion chargers work off any household line voltage from 90 to 240V 50/60Hz. Indicator lights show red when charging, flashing red if there is a fault, and green when the battery is fully charged. A line cord is included. They are designed to apply the correct type of charging current based on the charge status of the battery. It is OK to leave Li-Ion chargers plugged in all the time.

CHARGER1 (not shown) is rated at 1.5A charging current. It has a fixed 14.8V output to charge only 14.8V batteries.

CHARGER2 (shown below) is rated at 1.0A charging current. It is designed to charge 3.7V, 7.4V, 11.1V or 14.8V Lithium batteries. It will automatically detect and set itself for the proper battery voltage.



Part#	Description
CHARGER1r....	14.8V @1.5A Charger
CHARGER2r....	Auto Select 3.7V - 14.8V @1A Charger

*Sorry but Li-Ion Batteries cannot be shipped outside of the USA

3.7V @2Ah BAT4

The BAT4 is used in the T6000 and the T2300 wireless controllers.

We have found that it also makes a great building block for smaller scale battery packs. Connect 3 in series for 11.1V which is perfect for HO scale. Or use a boost module to raise the voltage to 12 volts. See back page for the boost module.

The cell measures 2.0 x 1.6 x 0.3 inches and weights about one-half ounce. It comes with a 2mm plug which matches to CVP's 2mm socket. Use the CHARGER2 to recharge the battery.

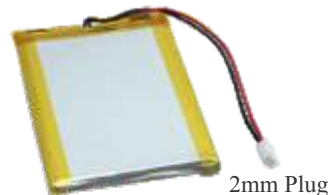

Part#	Description
BAT4r	3.7V 2Ah Li-Ion Cell
5PAKFr.....	Matching socket

T6000 Decoder Programmer and Operator Throttle

The new T6000 Wireless Controller is a full featured AirWire throttle suitable for decoder programming and locomotive operation. It has a long-lasting, rechargeable, Li-Ion battery. It has a rugged and sunlight readable display. It has the popular single-turn speed control and a dedicated direction key. Uses a standard microUSB charging cable and charger.

Built-In DCC Decoder Programmer

The T6000 will always be your first AirWire Controller. It is used to setup and program all AirWire decoders or any 3rd party DCC decoders used with AirWire.

Sleek Comfortable Case

The classic tall skinny case has been specially designed for hours of operation. It fits the smaller hands of younger operators whether they be right or left handed. The case measures 1 inch thick, 6 inches tall and 2 inches wide.

Big Locomotive Memory

The T6000 can hold up to 16 locomotive numbers in its large memory. It can store up to 3 different multi-unit consists with up to 4 locomotives each.

29 Function Keys

Activate all of your favorite decoder functions. There are 29 function keys just a keystroke away.

Part#	Description
T6000AWCr....	T6000 with charger and charging cable
T6000AWXr....	T6000 without charger or charging cable



T2300 Operator Throttle

Designed For Operation Only - Does Not Program Decoders

The OPS throttle cannot program decoders so you will need at least one T6000 throttle to setup and program your decoders. But, once programmed, the T2300 OPS throttle can take it from there.

Simple Operation and Superb Features

The T2300 is simple and easy to use. The rugged design is perfect for youngsters and guests. A conventional single turn speed control offers smooth yet precise control of your locomotive's speed and is rugged enough to withstand constant use and abuse from your young and young-at-heart operators.

Handy LMEM (SWAP) Key

Switching back and forth between two different locomotives is simple. Just push the LMEM key to change back to the previous locomotive number. Each locomotive can be on different frequencies too.

20 Function Keys

Activate all of your favorite decoder functions. There are 20 function keys just a keystroke away. Plus, a new feature allows simultaneous control of your locomotive and all 20 function keys while controlling turnouts and accessories.

Part#	Description
T2300AWCr....	T2300 with charger and charging cable
T2300AWXr....	T2300 without charger or charging cable



AirWire Decoders And CONVRTRs

Because AIRWIRE is based on the NMRA-DCC standard, you have a variety of decoder options from which to choose for wirelessly controlling your battery powered locomotive using an AirWire Wireless Controller.

All AIRWIRE Decoders include the radio receiver, the motor driver as well as the locomotive light drivers. For sound effects, there is a DCC booster output to drive DCC compliant sound modules and decoders. Some AIRWIRE decoders are designed to drop into specific brands and locomotive models. If we don't have a specific model for your locomotive, the generic G4X decoder is for you.

AIRWIRE CONVRTRs include the radio receiver and a DCC booster output. The CONVRTR allows any NMRA-DCC compliant decoder to be programmed and operated by an AIRWIRE throttle. Select the CONVRTR based on the amperage rating of the DCC decoder. The most popular combination is an AIRWIRE CONVRTR connected to a Soundtraxx, or a Train Control Systems (TCS) decoder. The attached DCC decoder provides the sound effects, motor drive and lighting control.

Choosing whether to use a CONVRTR or a standard AIRWIRE Decoder, depends on the locomotive requirements, and your preferences. For high current garden railroad locomotives, the Drop-In decoder or the G4X decoder provide up to 10 Amps of motor drive current and support rechargeable batteries up to 22 volts. The highest amperage DCC decoder from other manufacturers is only 5 amps and many are not rated for higher battery voltages. You must check the DCC decoder specifications to insure the ratings are not exceeded.

Smaller scale locomotives often come with pre-installed DCC decoders. These are the easiest locomotives to convert to AIRWIRE. Simply remove the track pickups and connect the DCC decoder track inputs to an AIRWIRE CONVRTR. Find space for the battery and you are done.

The hookup diagram shows an AIRWIRE C15 CONVRTR connected to a DCC sound decoder with an 11.1V battery for the power source. For most HO locomotives, a 1.0A DCC decoder paired with the C15 CONVRTR makes an ideal combination.

Typical C15 CONVRTR™ Hookup For HO Locos

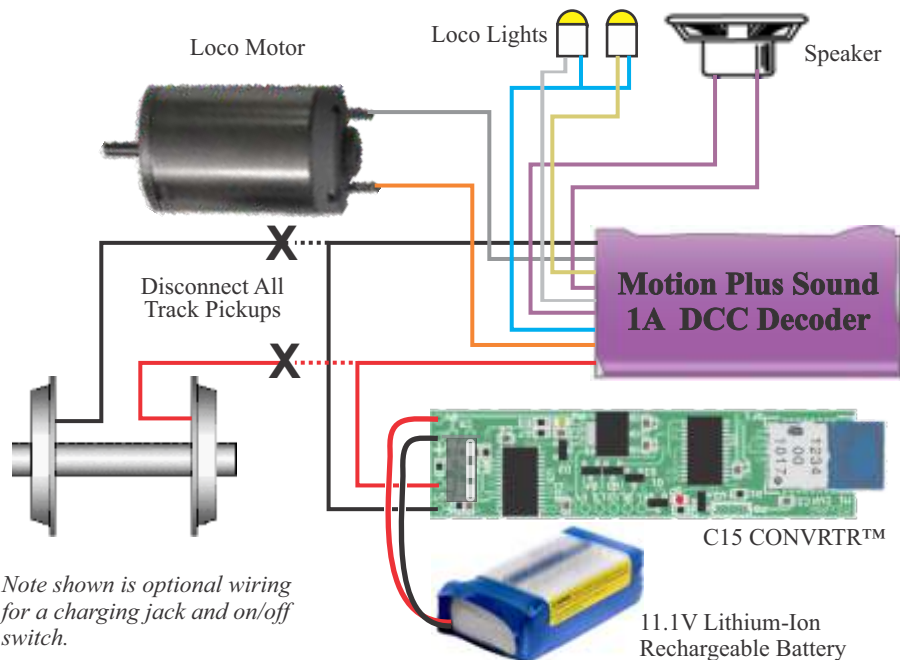

TURNOUT & ACCESSORY CONTROL

LINKER and ACTIVATOR



Remote control of turnouts and many types of accessories is easily accomplished with the combination of a single **AIRWIRE Linker** and one or more **AIRWIRE Activators**. Together, the Linker and Activator allow your wireless throttle to control items such as switch machines, lights, pumps, relays, solenoids or just about any other type of device found on a typical garden railroad.

The Linker

A basic setup consists of a Linker, which is the radio receiver, plus a power supply (battery or adapter) and the Activator which controls the turnouts or accessories. Each Activator can control 4 independent turnouts or accessories.

The Linker scans all **AIRWIRE** frequencies and combines the received activation commands with DC power and sends the combined signal to the companion Activators using a single pair of wires. The Linker can use either a 14.8V battery or a 15VDC power supply like the DCPS120 power supply.

All setup and option selection is done with the front panel switches. The 4 switches allow for selecting the scanned frequencies or to lock out certain frequencies.

All wire connections to the Linker are through plug-in terminal blocks. All wires can be connected or disconnected at one time by simply plugging or unplugging. Multiple Linkers can be used on a large railroad where there is a large distance between clusters of turnouts. Only a single Linker is needed to control and supply power to as many as 25 Activators.

The Activator

The Activator uses a single pair of wires, that connects it back to the Linker's DCC output. Multiple Activators can share the Linker's output. No power supply is needed. Power for the Activator comes directly from the Linker. All Activators share the same pair of wires and power source coming from the Linker.

The Activator can control four independent accessories such as switch machines. It can also control lights, signals, stationary motors, pumps and relays. The Activator is compatible with all types of switch machine motors including air-actuated machines. It can also control power relays and solenoids.

The Activator can be purchased in a custom plastic case with removable plug blocks. It is also available without the case and standard screw terminal strips.

Part#	Description
LNKRr	AirWire Linker
ACTr	AirWire Activator - with case
ACTXr	AirWire Activator - circuit board only, no case
DCPS120r	120W DC Power Supply with selectable output voltage



XDRIVE Hookup Example

The XDRIVE receives power and DCC signal from the Drop-In decoder by way of the harness. The example shown uses the SD70 Drop-In Decoder.

Plug either end of the harness into the Sound socket on the Drop-In.

Plug the other end of the harness into the socket on the XDRIVE.

If the harness wire are too long, coil up the excess wire and tuck it out of the way.

Mount the XDRIVE in an area away from the radio module and antenna. Make sure the bottom of the module does not contact any metal object.

Decide where to mount the sound module. Trim the XDRIVE output socket's wire to the desired length. Strip and tin the wire ends. Insert the two wires into the LR and RR track inputs of the TSU4400 decoder.

Do not use the DCC decoder's motor drive output if present. There is insufficient power from the Drop-In to do so and can damage the Drop-In board.

You may use the DCC sound decoder's light drivers. See the manufacturers DCC sound decoder's user manual for more information and how to setup and connect LEDs to the drivers.



SD70 Drop-In

Harness plugs are polarized. They fit only one way. Do not force them into board sockets.



XDRIVE

The SD40 Drop-In Includes a Built-In XDRIVE

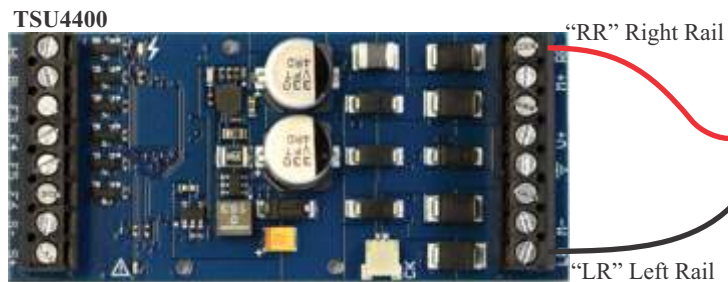

TSU4400

"RR" Right Rail

"LR" Left Rail

The XDRIVE includes a pre-attached 2mm plug and socket for easy hookup to the sound decoder.

Not For Use On First Gen Drop-Ins

Older Drop-In decoders having the vertical radio module or the black plastic radio receiver, cannot program attached DCC decoders and do not have the correct polarity for the XDRIVE harness. The XDRIVE cannot be used on these older Drop-In decoders.

New Plug-In CONVRTRs For Bachmann Locos

Meet the new series of Plug-In CONVRTRs, specifically designed for Bachmann large scale steam engines (B60X) as well as their newest release, the GE Dash 9 locomotive (D60X). A game-changer in the world of model trains, our new series of CONVRTRs allows for easy connection of 3rd party DCC sound decoders and converts them into AIRWIRE compatible decoders.

Designed For Bachmann Large Scale Locomotives Converting the locomotive to battery power is easy when you combine the existing Bachmann RC/DCC socket with the new AirWire 900 Plug-In CONVRTR. Just plug it in!

Effortless Installation Installation is a breeze with our full color illustrated Installation Guide. All connectors, wiring harnesses, hardware and special tools are included in the Plug-In CONVRTR installation kit.

Easily Connect 3rd Party DCC decoders Connections between the sound decoder and the Plug-In CONVRTR are done using the included wiring harnesses. You will find wire ends are already stripped and tinned. All you need is a screwdriver - no soldering is required.

Alleviate Your Concerns The new series of Plug-In CONVRTRs work seamlessly with all AirWire900 Wireless Controllers and throttles.

Below is a photo of the new B60X Plug-In CONVRTR installed in a Bachmann 4-6-0 Big Hauler. The DCC sound decoder comes from Soundtraxx although almost any NMRA-DCC decoder can be used. The BAT3 is also shown as it fits neatly into the tender in the space available.

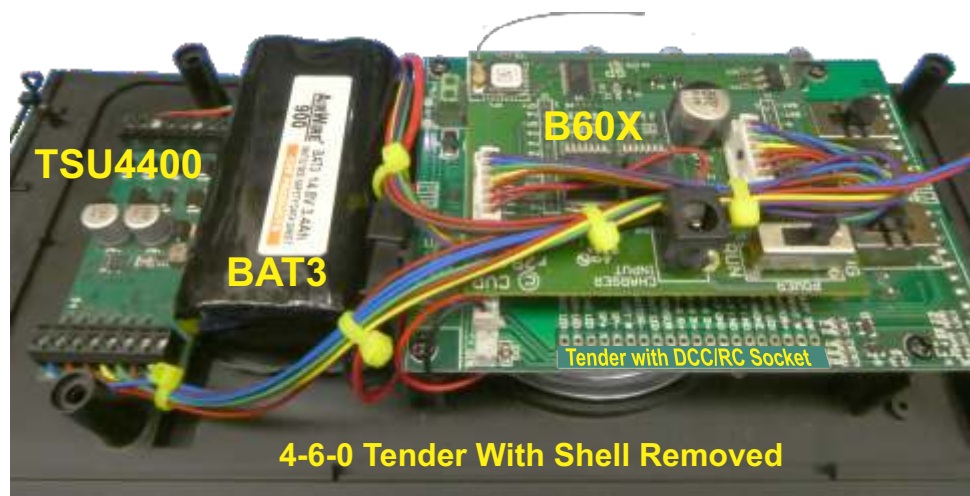

4-6-0 Tender With Shell Removed

The Installation Guide Is Written for First Timers!

With plenty of photos and detailed pictorials, almost anybody can successfully install AirWire into their Bachmann locomotive

All you need to know is how to follow instructions. You do not need any knowledge of electronics or computers.

In addition to including all the required wires, pigtails, hardware and tools in the Plug-In CONVRTR kit, it also comes with a colorful and fully illustrated installation guide.

Instructions are written assuming you know nothing. The guide starts with how to remove the fragile locomotive from its shipping contained and finishes with how to put it all back together again.

Download a copy of the instructions from our website and see for yourself.

B60X - 6 Amp Rating

The B60X is designed to plug into existing, factory installed DCC/RC socket found in Bachmann steam engines. In case you are wondering, the "B" designation means "boiler."

The illustrated B60X Installation Guide uses the Bachmann 4-6-0 Big Hauler for the example installation. The B60X also fits the K27/C19 Narrow Gauge locomotives. Other Bachmann Steam engines can also use the B60X once you have determined where to place the battery.

The B60X has a 6A continuous output current rating. It has plenty of power for all 3rd party DCC sound decoders sold for large scale locomotives. It has a surge current rating of a whopping 55 Amps. The maximum input voltage is 22 volts.

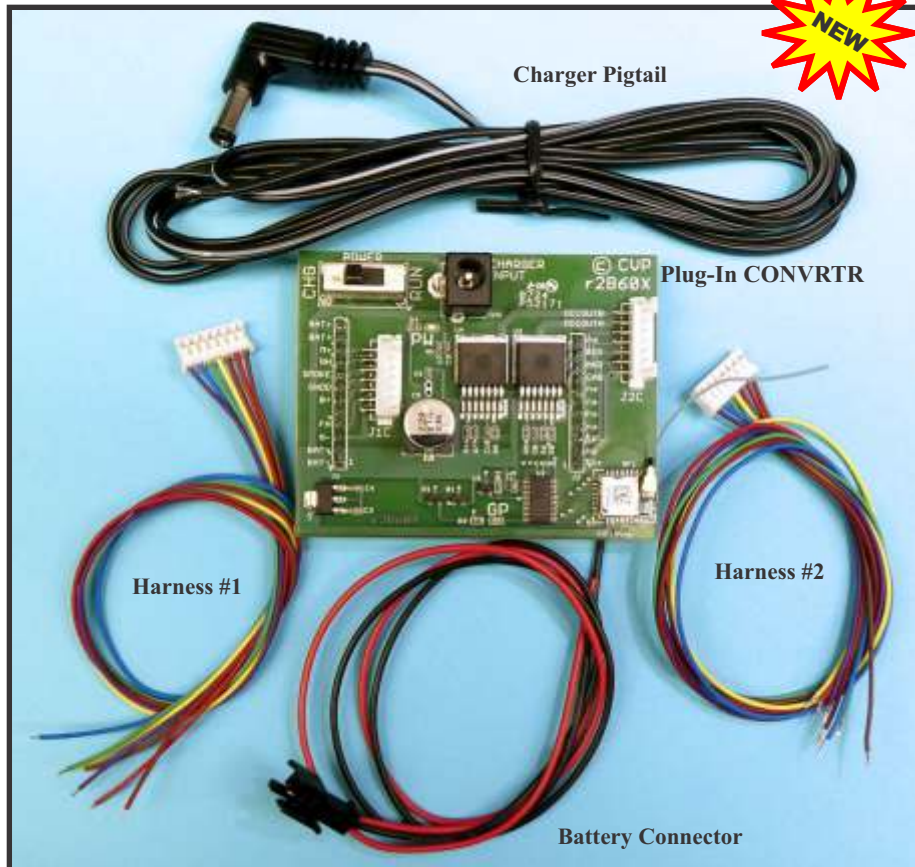

Part#	Description
-------	-------------

B60Xr	Plug-In CONVRTR for Bachmann Steam Engines Includes the Plug-In Convrtr circuit board, Installation Guide, battery connector, battery charger connector, and two wiring harnesses. <i>Requires a suitable battery, and a 3rd party DCC sound decoder of your choice.</i>
-----------------	--

AIRWIRE Motion Decoders Small Enough For HO scale!

From the acknowledged experts in wireless, battery powered model railroading, comes a new series of AIRWIRE decoders small enough for HO scale.

Using onboard batteries makes railroading fun again. Imagine no layout wiring, no reverse loop nightmares, and no track or wheel cleaning. Best of all, a stuttering or constantly stalling locomotive will run smoothly since it no longer relies on its poor pickups and wheels for power.

More importantly, there is no need to purchase additional DCC programming equipment because our most popular T5000 AirWire throttle is also a complete, self-contained DCC programmer. Use the T5000 to easily select and setup all of the decoder's options and fine tune its operation.

M15 - 1.5Amp microDecoder

- ▶ Radio Receiver and DCC Motion Decoder
- ▶ 1.5A Continuous, 5A Peak
- ▶ Protected Against Overloads & Overheating
- ▶ 17 User Selectable Frequencies
- ▶ 9999 Addresses per Frequency
- ▶ Front & Rear Headlight + 2 Aux LED drivers
- ▶ Lighting Effects and Headlight Direction Modes
- ▶ 10V to 18V Battery Range
- ▶ Precision Motor Drive With Cruise Control
- ▶ Select Either Internal Or External Antenna

M15 Internal Antenna

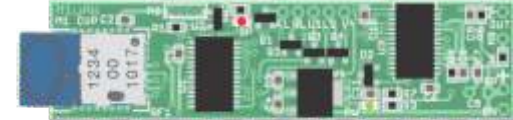

Actual Size! 0.6 x 2.4 x 0.25 inches

M15X External Whip Antenna

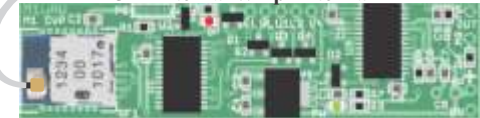

Part#	Description
-------	-------------

M15r . . .	1.5A microMotion Decoder with Internal Antenna
M15Xr . .	1.5A microMotion Decoder with External Antenna



Most USA-Trains Drop-Ins require an optional board to amplify the DCC signal for an external NMRA-DCC sound decoder. This optional board is called the XDRIVE.

The XDRIVE board provides DCC signal and power to your selected sound decoder. We recommend either a Soundtraxx or TCS decoder. The XDRIVE comes complete with the required plug-in harness to fit the AirWire decoder. The XDRIVE also includes a pre-installed connector for easy connection to the DCC sound decoder.

If your Drop-In is a USA-Trains S4 switch engine, be sure to get the XDRIVES4 version. It includes a different connection harness.

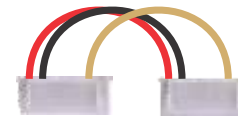

Drop-In To XDRIVE Harness Included

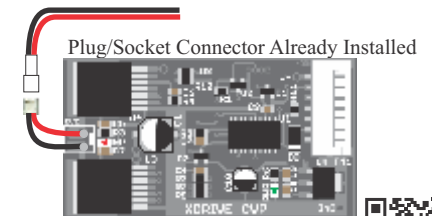

Part#	Description
-------	-------------

XDRIVER . . .	Optional Drop-In External DCC Decoder Driver with Standard Harness
XDRIVESr . .	Optional Drop-In External DCC Decoder Driver with S4 Harness



ADAPTA23

Bachmann and Aristo DCC/RC Socket Expander



The AD23 makes it easy to connect from your locomotive's built-in DCC/RC socket to your favorite DCC decoder. Stripped and tinned wires greatly simplifies decoder hookup.

- ▶ For locos with built-in DCC/RC Socket
- ▶ Easily access All 21 Active Pins
- ▶ Includes three separate wiring harnesses
- ▶ Wires are pre-stripped and tinned
- ▶ For use with any 3rd party DCC decoder
- ▶ Small size with low profile
- ▶ Fully assembled

Part#	Description
AD23r....	DCC/RC Socket Plug



DECODERS

USA TRAINS DROP-IN™ DECODERS

The USA-Trains Drop-In Decoders are designed for specific locomotives made by USA-Trains. The locomotive must have its original factory wiring for a Drop-In to work correctly. Each Drop-In comes with a full color Installation Guide as well as a detailed User Guide.

The SD40 Drop-In has a built-in XDRIVE for use with any DCC sound decoder. Other Drop-Ins require the XDRIVE board to allow any NMRA-DCC decoder to be used with the Drop-In.

- ▶ Uses Original Factory Wiring
- ▶ Easy Drop-In Mounting
- ▶ Socket for XDRIVE
- ▶ Built-in Battery Charging Jack
- ▶ Power Switches For Sound and Decoder
- ▶ 17 Independent Radio Frequencies
- ▶ Remote Frequency Setting
- ▶ More Light Driver Outputs
- ▶ Ditch Light/Safety Light Drivers
- ▶ 120 Watt Protected Motor Drive
- ▶ Cruise Control
- ▶ Easily Fine Tune Motor Performance
- ▶ Independent Control Of All Lighting
- ▶ 3A Smoke Driver With Shutoff Timer
- ▶ Program DCC Sound Decoder
- ▶ Battery Connector For CVP Batteries
- ▶ Works With All AirWire Throttles
- ▶ Separate Installation and User Guide

Part# Description

F3/F7r	Drop-In Decoder for USA-Trains F3A/B and F7A/B
GP7-9r	Drop-In Decoder For USA-Trains GP7 or GP9
GP30r	Drop-In Decoder for USA-Trains GP30
GP38r	Drop-In Decoder for USA-Trains GP38-2
NW2r	Drop-In Decoder for USA-Trains NW2
PABr	Drop-In Decoder for USA-Trains PA/PB
S4r	Drop-In Decoder for USA-Trains S4
SD70r	Drop-In Decoder for USA-Trains SD70MAC
SD40r	Drop-In Decoder for USA-Trains SD40-2 (with built-in XDRIVE)

If your USA-Trains locomotive is not listed, use the G4X decoder or a CONVRTR plus a 3rd party DCC decoder.



Download Installation and/or User Guides From cvpusa.com

CONVRTR™

D60X Plug-In

D60X - 6 Amp Rating

The D60X is designed to plug into the existing, factory installed DCC/RC socket, found in the latest Bachmann GE Dash 9 diesel locomotive. In case you are wondering, the "D" designation means "Dash 9 Diesel."

The D60X has a 6A continuous output current rating. It has plenty of power for all 3rd party DCC sound decoders sold for large scale locomotives. It has a surge current rating of a whopping 55 Amps. The maximum input voltage is 22 volts.

The fully illustrated D60X Installation Guide provides complete details for how to install, plug-in and hookup the two circuit boards that make up the D60X. The kit includes all of the wiring harnesses, plus the small 0.9mm hex wrench to fit the metric screws included in the hardware kit.

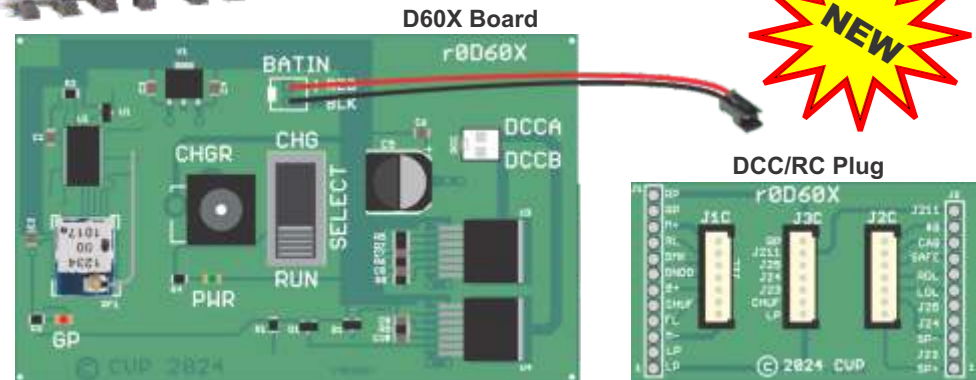

The D60X board mounts under the roof access hatch using the included hardware kit. This makes accessing the charger jack and the selector switch very convenient. The 3rd party sound decoder mounts beneath the DCC/RC socket and is wired to the D60X DCC/RC plug with the included wiring harnesses. There is enough room to mount a BAT2 inside the loco.

Wiring Harness (2)

DCC Pigtail

Charger Pigtail

Hardware Kit



Part# Description

D60Xr	Plug-In CONVRTR for Bachmann GE Dash 9
-----------------	--

Includes the DCC/RC Plug, D60X board, Installation Guide, battery charger connector, DCC Connector, two wiring harnesses, and extra hardware kit

Requires a suitable battery, and a 3rd party DCC sound decoder of your choice.

The CONVRTR™ series of products, allows any NMRA-DCC compliant decoder to become an AIRWIRE compatible decoder. Take advantage of the pre-installed NMRA-DCC decoders found in a wide range of locomotives. With the simple addition of a CONVRTR and a battery, the locomotive becomes an AIRWIRE locomotive.



All of the attached decoder's features and functions are controlled directly from an AIRWIRE throttle. There are absolutely no changes to the decoder. A bonus feature is that the T6000 AIRWIRE throttle is used to setup and program the DCC decoder. There is no need to purchase any other DCC equipment.

Each CONVRTR (Converter) is an ultraminiature radio receiver plus a DCC booster. Verify your DCC Decoder amperage rating is **less** than or equal to the CONVRTR rating. The DCC decoder amperage rating must not be rated higher than the CONVRTR rating.

Download the CONVRTR user guides from our website and see how easy it is to install and use one.

C15 - 1.5 Amp Rating

The C15 is rated at 1.5A continuous and 5A peak. Maximum input voltage is 18 volts. Unlimited surge current. The circuit board measures only 2.4 inches long and 0.6 inches wide. The X version has an antenna jack for use with the included 3-inch long whip antenna.

Part#	Description
C15r	1.5A CONVRTR Internal Antenna
C15Xr	1.5A CONVRTR External Antenna

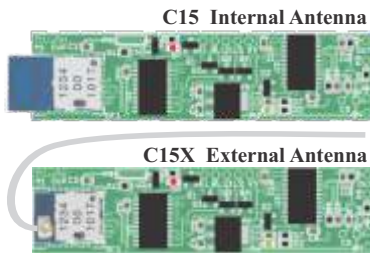

C25 - 3.0 Amp Rating

The C25 is rated at 2.5A maximum continuous current. Maximum input voltage is 22 volts. The circuit board measures 2 inches long and 0.9 inches wide. The X version has an antenna jack for use with the included 3-inch long whip antenna.

Part#	Description
C25r	2.5A CONVRTR with Internal Antenna
C25Xr	2.5A CONVRTR with External Antenna

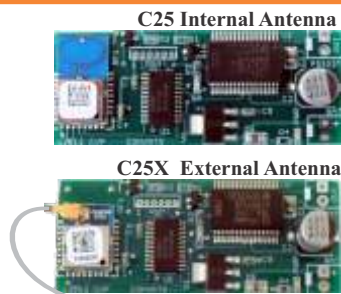

C60 - 6 Amp Rating

The C60 is one of our most powerful CONVRTRs. The maximum continuous current rating is 6 Amps. It has a surge current rating of a whopping 55 Amps. The circuit board measures only 2.2 inches long and 1.2 inches wide.

All connections are made to the miniature screw terminal strips (not shown in the pictures).

The maximum input voltage is 24 volts.

Part#	Description
C60r	6.0A CONVRTR with Internal Antenna
C60Xr	6.0A CONVRTR with External Antenna

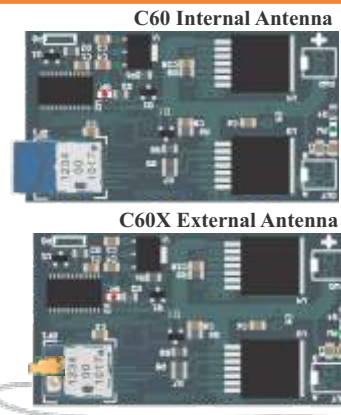

A higher current rated CONVRTR can always be used with a lower current rated DCC decoder.

High Power Motion Decoder with 120 Watt Motor Drive

The G4X decoder is a complete, self-contained radio receiver and motion decoder that offers both small size and big power. It is the 4th generation of our popular motion decoder series and features many novel and often requested features.

The heart of the G4X decoder is a new motor driver circuit suitable for locomotives having multiple motors. In addition to its 120 Watt power rating, it has robust protection to the motor driver. It is suitable for all large scale locomotives. Heavy duty terminal blocks makes wiring easy.

Also built in is a 2.5amp DCC booster that provides power and command signals for NMRA-DCC compatible sound modules. The DCC output also works with other types of NMRA-DCC decoders such as multi-function decoders. A pair of screw terminals [labeled DCC] makes hookup simple.

The G4X offers many lighting and special effects outputs. It includes 6 programmable light driver outputs in addition to the standard front and rear headlight outputs. The G4X also includes front and rear drivers for the Phoenix brand of remote couplers.

Connections to the lights, smoke generators and couplers are made with two separate pluggable wire harnesses. The sockets have logical groupings of the light outputs. A double-ended wiring harnesses **is included** with the G4X. It is cut into two pieces to make two separate harnesses.



- ▶ G4X is Small, only 1.4in x 4.0in
- ▶ Frequency Is Set From Throttle
- ▶ 17 Independent Radio Frequencies
- ▶ Easy Speed Matching
- ▶ Smooth, Quiet, Precision Motor Drive
- ▶ 120W Motor Driver Fully Protected
- ▶ Cruise Control
- ▶ Ditch/Safety Lights Driver
- ▶ High Power Smoke Generator with selectable timer
- ▶ 16 Special Lighting Effects
- ▶ Built-in Drivers for Phoenix Solenoid Couplers
- ▶ Two 6-conductor Miniature Sockets for all Lighting
- ▶ Works with all NMRA-DCC Sound Decoders
- ▶ Printed, Comprehensive User's Guide included

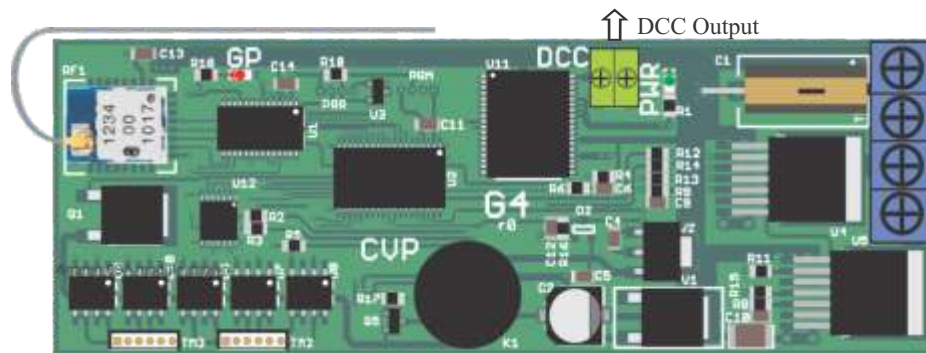

- ↑ DCC Output
- TM2-1 Front Headlight
- TM2-2 Rear Headlight
- TM2-3 Ditchlight (right)
- TM2-4 Ditchlight (left)
- TM2-5 AUX Lite #1
- TM2-6 AUX Lite #2
- TM3-1 AUX Lite #3
- TM3-2 AUX Lite #4
- TM3-3 Front Coupler
- TM3-4 Rear Coupler
- TM3-5 Smoke Driver
- TM3-6 Coupler Voltage [VDR]

Part#	Description
G4Xr.....	Motion Decoder with Whip Antenna, Wiring Harness and Terminal Blocks
G4Hr.....	Replacement TM2 and TM3 Harness [makes two cables]

